

SPINNING REEL — PS1600BL/2000BL

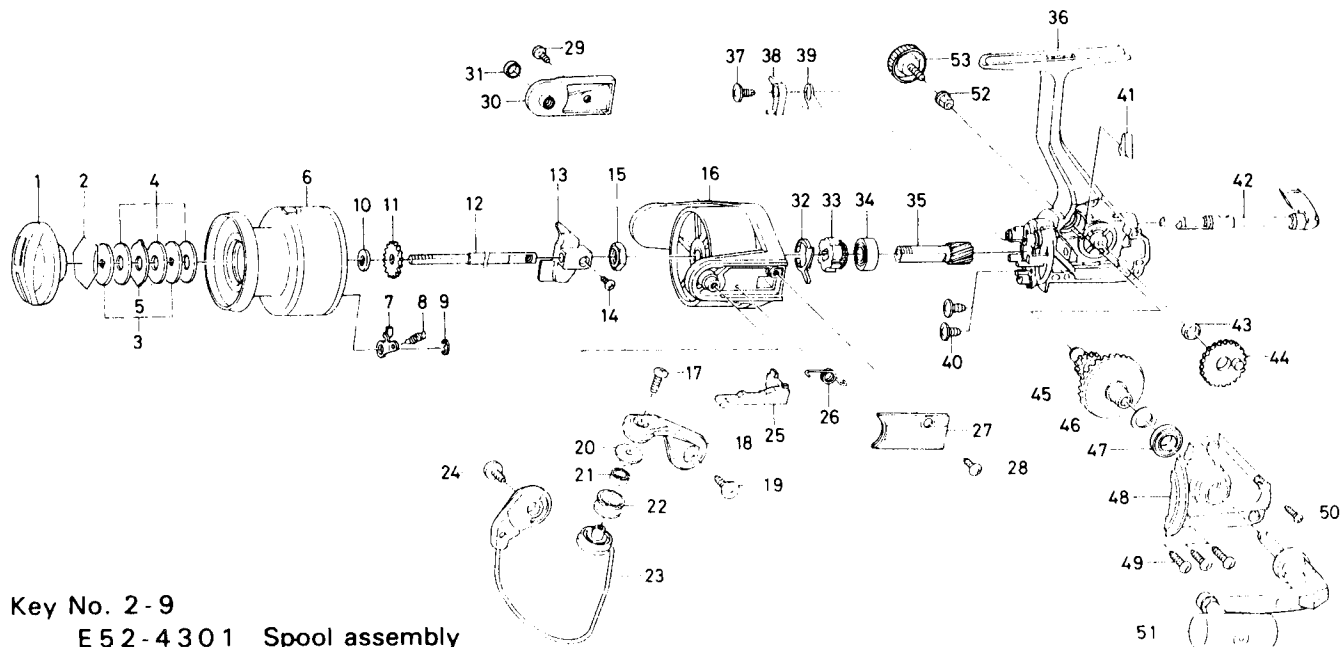

Key No. 2-9
E 52-4301 Spool assembly

Key No.	Parts No.	Parts Name
1	F 19-8801	Drag knob
2	171-7701	Drag washer retainer
3	F 09-4901	Key washer
4	E 13-6003	Drag washer
5	373-3603	Eared washer
6	E 52-4401	Spool assembly
7	B 07-5304	Click pawl
8	E 40-3101	Click spring
9	320-5901	Click retainer
10	F 09-4701	Spool washer
11	E 46-2701	Click gear
12	E 48-5301	Main shaft
13	F 09-1301	Oscillating slider
14	352-1502	Oscillating block screw
15	340-6602	Rotor nut
16	F 10-6604	Rotor
17	B 67-9305	Line roller screw
18	E 50-4802	Bail arm
19	E 00-7102	Bail arm screw
20	F 06-6301	Line roller collar
21	F 05-5601	Ball bearing A
22	F 05-8901	Line roller
23	F 19-4101	Bail assembly
24	B 51-5302	Bail trip cam screw
25	E 46-2101	Bail trip lever
26	F 12-8901	Bail spring
27	E 46-2201	Bail spring cover

Key No.	Parts No.	Parts Name
28	E 36-4201	Bail spring cover screw
29	L 01-1701	Bail trip cover screw
30	F 19-4001	Bail trip cover
31	F 17-3001	Bail trip collar
32	E 46-2001	Anti-reverse pawl spring A
33	E 46-1901	Anti-reverse ratchet
34	L 03-6502	Ball bearing B
35	E 52-0101	Pinion gear
36	F 19-3801	Body assembly
37	E 00-7101	Anti-reverse pawl screw
38	E 46-1302	Anti-reverse pawl
39	E 46-1201	Anti-reverse pawl spring B
40	E 03-7801	Bearing retainer screw
41	E 32-7801	Anti-reverse cam spring
42	F 08-5119	Anti-reverse lever
43	F 13-1601	Oscillating gear collar
44	E 46-1501	Oscillating gear
45	E 52-0201	Drive gear
46	373-7800	Drive gear washer
47	631-6901	Ball bearing C
48	E 50-5605	Side cover
49	B 83-5001	Side cover screw A
50	E 15-8601	Side cover screw B
51	L 05-0102	Handle assembly
52	E 12-7501	Handle collar
53	B 92-5002	Handle lock screw

SPINNING REEL — PS1600BL/2000BL

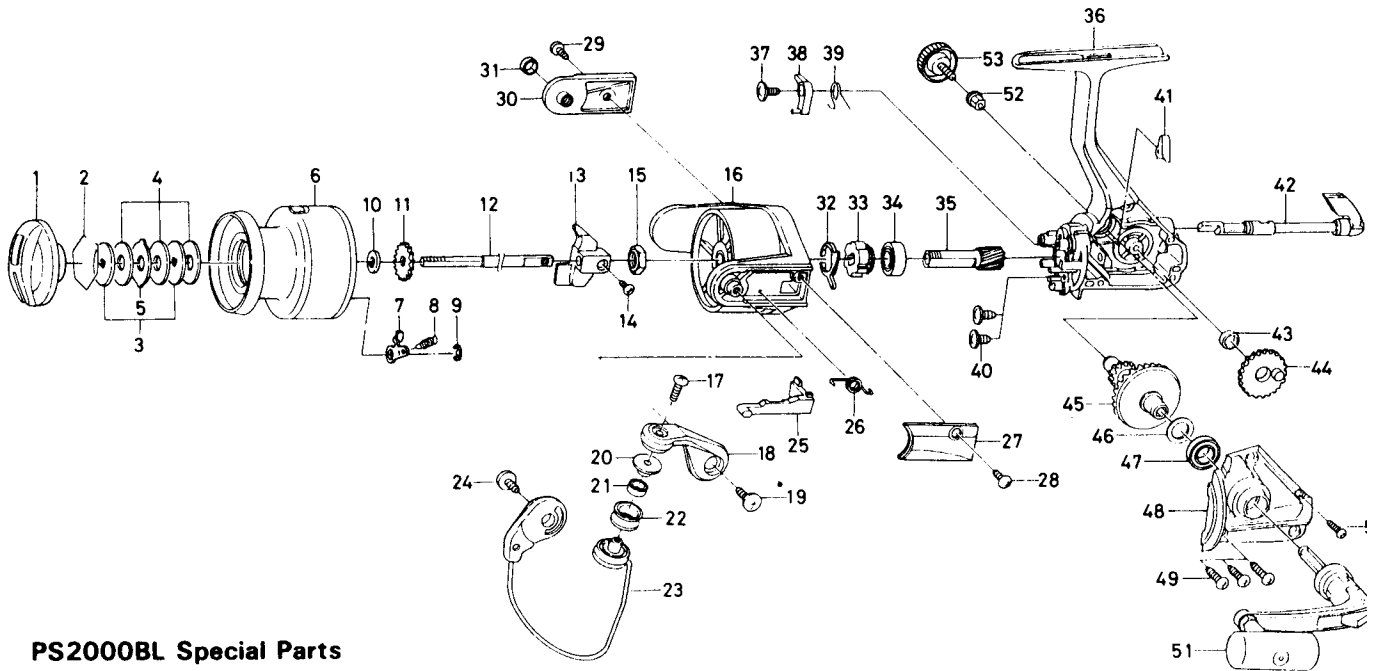

PS2000BL Special Parts

Key No.	Parts No.	Parts Name
2-9	E 52-4501	Spool assembly
6	E 52-4601	Spool assembly
16	F 10-7205	Rotor
23	F 19-4501	Bail assembly
25	E 46-3101	Bail trip lever
36	F 19-3803	Body assembly
48	E 50-5704	Side cover