

**RIPTIDE 50
RT50**

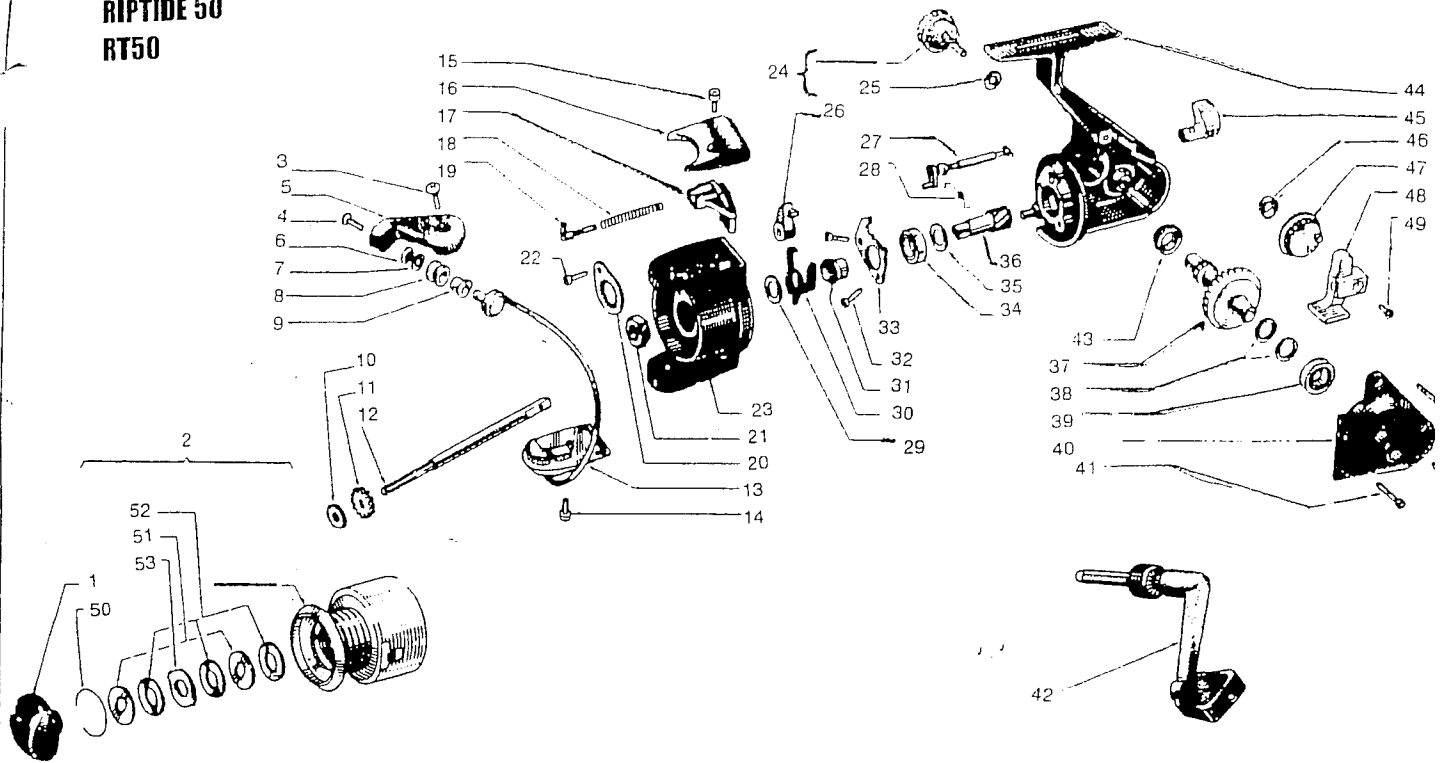

ITEM#	MIP PART #	DESCRIPTION	ITEM#	MIP PART #	DESCRIPTION	ITEM#	MIP PART #	DESCRIPTION
1	RT50-1	DRAG KNOB	21	RT30-21	HEX NUT	41	RT30-41	COVER PLATE SCREW
2	RT50-2	COMPLETE SPOOL	22	RT30-22	SCREW	42	RT50-42	HANDLE
3	RT30-3	SCREW, BAIL ARM	23	RT50-23	ROTOR	43	RT30-43	BUSHING
4	RT50-4	BAIL SCREW	24	RT30-24	HANDLE CAP SCREW	44	RT50-44	HOUSING
5	RT50-5	BAIL ARM	25	RT30-25	HANDLE CAP SCREW WASHER	45	RT50-45	A/R SWITCH
6	RT30-6	LINE GUIDE RACE	26	RT50-26	A/R CAM	46	RT30-46	BUSHING
7	RT30-7	WASHER, LINE ROLLER	27	RT50-27	A/R SHAFT	47	RT50-47	OSC GEAR
8	RT30-8	LINE GUIDE	28	RT30-28	A/R SPRING	48	RT50-48	O/S SLIDER
9	RT30-9	LINE GUIDE BUSHING	29	RT50-29	A/R FRICTION WASHER	49	RT50-49	OSCILLATION SLIDE SC
10	RT50-10	WASHER	30	RT50-30	A/R FRICTION	50	RT50-50	DRAG RETAINER
11	RT50-11	SHAFT RATCHET	31	RT30-31	AR FRICTION BUSHING	51	RT50-51	METAL WASHER
12	RT50-12	AXLE	32	RT30-32	SCREW	52	RT50-52	DRAG WASHER
13	RT50-13	BAIL	33	RT50-33	BEARING RETAINER	53	RT50-53	WASHER, EARED DRAG
14	RT30-14	SCREW, RETAINING	34	RT30-34	BEARING			
15	RT30-15	SCREW	35	RT50-35	WASHER			
16	RT50-16	SIDE COVER	36	RT50-36	PINION GEAR			
17	RT50-17	TRIP LEVER	37	RT50-37	MAIN GEAR			
18	RT30-18	BAIL SPRING	38	RT30-38	SHIM, DRIVE GEAR			
19	RT50-19	BAIL SPRING PIN	39	RT30-39	BUSHING			
20	RT30-20	RING, HEX NUT LOCKING	40	RT50-40	SIDE PLATE			