



ZS1A

WARNING!!!

These parts are not interchangeable with previous model

SPECIFICATIONS:

- Ultra Light
- 125 yds./4 lb. Line Capacity
- Front Drag
- 4.4:1 Ratio
- 7.1 oz. Weight

FEATURES:

- Three-Way Silent (On/Off/Self-centering)
- Right/Left Interchangeable Handle
- Internal Bail Trip
- Rotating Line Roller
- Rugged Brass Pinion Gear
- Color: Black

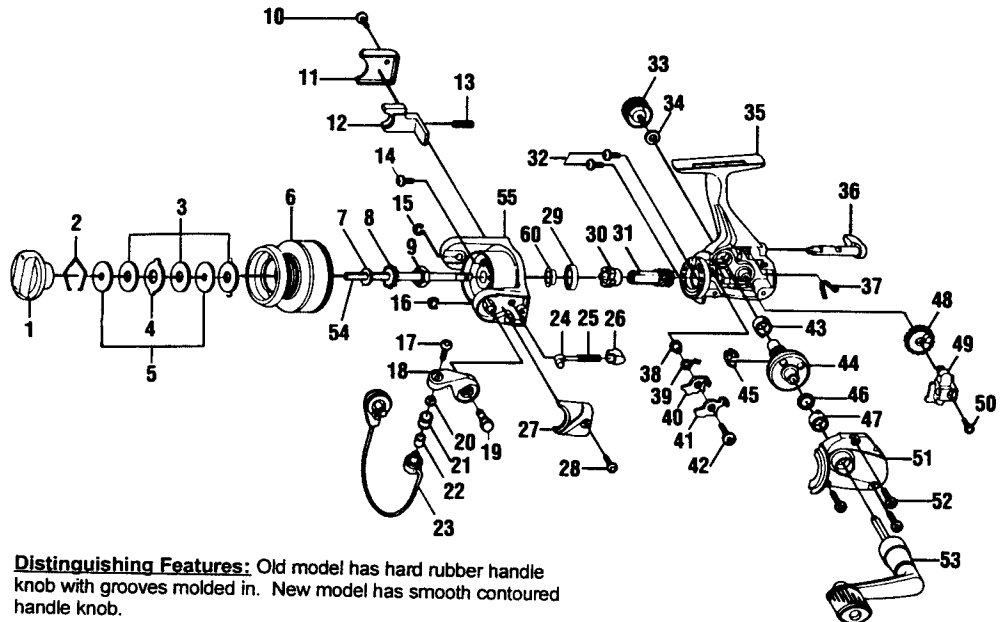

Distinguishing Features: Old model has hard rubber handle knob with grooves molded in. New model has smooth contoured handle knob.

Special Handling Instructions: If specific model version cannot be identified for parts order, send one of each part (for old and new model) and charge for one part.

Key No.	Part No.	Description	Price	Key No.	Part No.	Description	Price
1	GU332-01	Drag Knob Assembly	2.87	29	XU028-01	Pinion Bushing	
2	GU038-01	Drag Retainer	.27	30	HU060-01	Ratchet Gear	2.12
3	GU105-05	Drag Washer "B"	.68	31	GU011-01	Pinion Gear	1.70
4	GU081-01	Drag Washer "A"	.54	32	GU077-01	Bearing Screw	.14
5	GU080-01	Drag Washer "D"	.54	33	XU073-01	Handle Screw Cap	.64
6	GU321-15	Spool Assembly	.37	34	GU105-01	Handle Cap Washer	.10
7	GU105-06	Spool Adjustment Washer		35	XU001-03	Body	2.68
8	GU037-01	Click Gear	.54	36	KH090-01	Anti-Reverse Lever	1.53
9	GU006-01	Rotor Nut	.32	37	GU089-01	Anti-Reverse Lever Spring	.54
10	GU077-02	Kick Lever Cover Screw	.15	38	GU091-01	Anti-Reverse Pawl Post	.27
11	GU046-01	Kick Lever Cover	.22	39	GU061-01	Anti-Reverse Pawl Spring	.37
12	GU019-01	Kick Lever	.42	40	GU063-01	Anti-Reverse Pawl "A"	.47
13	KQ049-01	Kick Lever Spring	.27	41	GU074-01	Anti-Reverse Pawl "B"	.47
14	GU077-08	Rotor Nut Lock Screw	.15	42	GU077-05	Anti-Reverse Pawl Screw	.15
15	GH034-01	E-Clip	.32	43	GU027-01	Gear Shaft Bushing	.84
16	GH034-01	E-Clip	.32	44	GU012-01	Drive Gear	2.97
17	AQ108-04	Line Slider Screw	.32	45	GU086-01	Silent Cam	.42
18	LU007-01	Arm Lever	.78	46	GU105-08	Drive Gear Adj. Washer	.15
19	XU051-01	Arm Lever Pin	.47	47	GU027-01	Body Cover Bushing	.84
20	GU105-07	Line Roller Washer	.15	48	GU053-01	Oscillator Gear	.91
21	GU004-01	Line Roller	1.24	49	GU025-01	Oscillator Slider	.91
22	MT016-01	Line Roller Bushing	.77	50	GU100-01	Main Shaft Screw	.15
23	GU347-02	Bail Assembly	3.77	51	XU023-03	Body Cover	2.78
24	KQ031-01	Bail Spring Shaft	.27	52	GU057-01	Body Cover Screw	.15
25	KQ049-03	Bail Spring	.32	53	XU318-01	Handle Assembly	2.32
26	QL020-01	Bail Spring Holder	.32	54	GU015-01	Main Shaft	1.91
27	LU087-01	Bail Spring Cover	.21	55	GU009-19	Rotor	1.91
28	GU077-02	Bail Cover Screw	.15	60	XU110-01	Pinion Collar	.46

MODEL INTRODUCED 1998	EFFECTIVE DATE OF PARTS LIST/DIAGRAM July 1998	DISCONTINUED N/A
------------------------------	---	-------------------------

Prices subject to change without notice. Prices do not include postage and handling.

PLEASE ORDER BY PART NUMBER Zebco Division Brunswick Corporation, Box 270, Tulsa, OK 74101 USA 918-831-6965

